

# Interrogator<sup>®</sup> 200 Audio Verification Module (AVM)

Document Number: 466-1621 Rev. A  
October 1998



60-787

## Installation Instructions

### Product Summary

The Interrogator 200 Audio Verification Module (AVM) gives the central station operator the ability to hear what's happening at the premises during an alarm and speak directly to the system owner. The operator can determine how serious an alarm is, find out what kind of help is needed, and dispatch the appropriate assistance.

Control Panel Compatibility: **SIMON™**  
Only **Version 2** (# 60-776)

### Installation Guidelines

Use the following guidelines when installing the AVM:

- You can install one AVM per panel.
- Wire speakers (voice terminals) in series and the DC voltage, ground, and microphone wires in parallel.
- Use separate cables for the speakers and the power, ground, and microphone wires to prevent cross talk between the microphone and the speaker.
- Use 3-conductor, 22-gauge shielded wire from the AVM power, ground and microphone to the panel. Shielded cable reduces electrical noise and cross talk.
- Use 2-conductor, 18-gauge wire from the speakers to the panel.

- Use a maximum of 500 feet of cable for all speakers and microphones.

### Tools Needed

- Phillips screwdriver
- Mounting screws and anchors (included)
- Drill and bits
- 3-conductor, 22-gauge shielded stranded wire
- 2-conductor, 18-gauge stranded wire

### Installation

#### To mount the AVM:

1. Route both 2 and 3-conductor wire cables from the module to the panel.
2. Remove the cover screws from the module cover and rotate it away from the base. Set the cover and screws aside.
3. Remove the speaker plate screws and lift the speaker plate off the back box (see Figure 1).

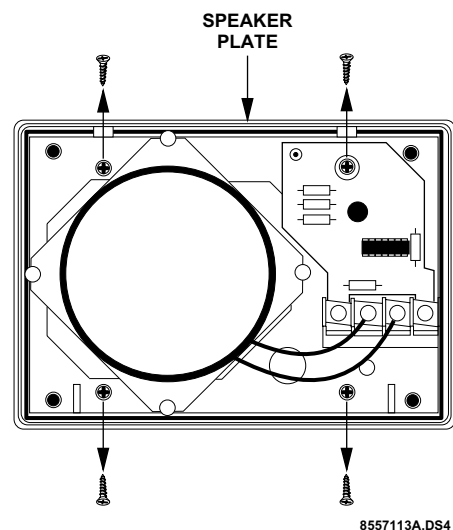
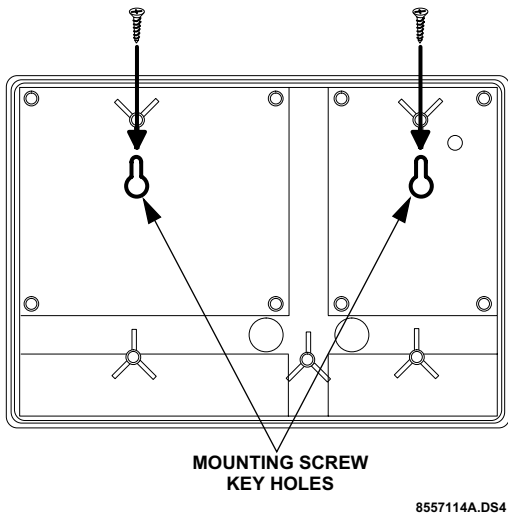

Figure 1. Removing the Speaker Plate

- Place the back box on the wall at the desired location and mark mounting holes (see Figure 2).



**Figure 2. Mounting Hole Locations**

- Install anchors if needed and secure the back box to the wall with the enclosed screws.
- Feed the cables through one of the cable holes in the back box (see Figure 3).

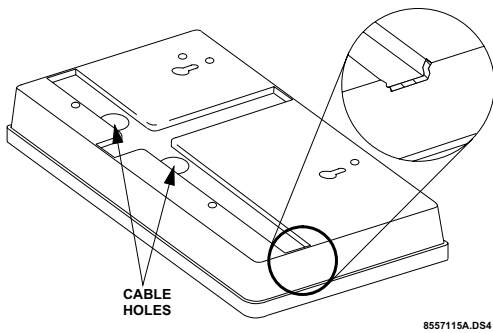

**Figure 3. Cable Holes and Channels**

- Align the back box mounting screw key holes with the two mounting screws and slide down.
- Level the back box and tighten the mounting screws.
- Feed the cable through the large hole on the speaker plate.
- Replace the speaker plate on the back box.

## Wiring the AVM to the Control Panel

To wire the AVM to the control panel:

- Unplug the transformer and the battery.

- Plug the panel cable, supplied with the AVM, into the back of the control panel.
- Connect terminals as shown in Figure 4. Use 18-gauge wire for speakers and 22-gauge for power, ground, and microphone.

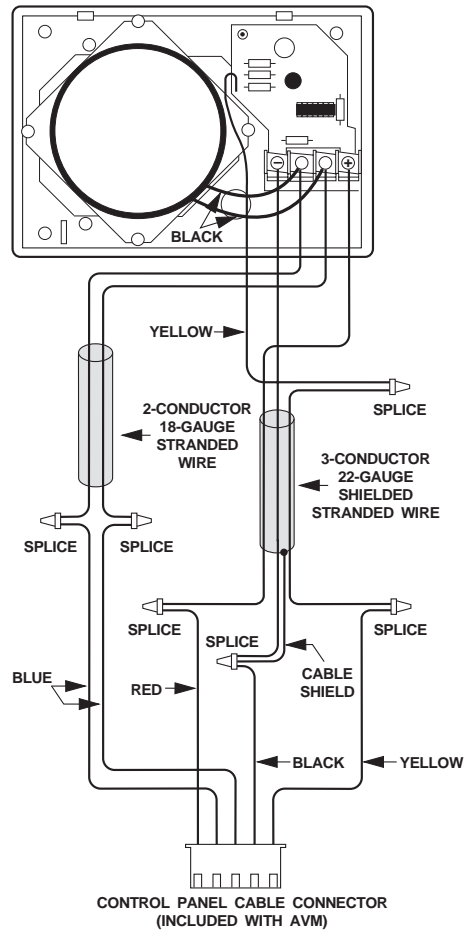

**Figure 4. Wiring the AVM to the Control Panel**

- Connect the black speaker wires on the AVM to the blue wires on the control panel cable using the 18 gauge wire.
- Connect power on the AVM to the red wire on the control panel cable using the 22 gauge wire.
- Connect the shielded cable drain wire (bare wire shown in Figure 5) to the black wire on the control panel cable and ground on the AVM.

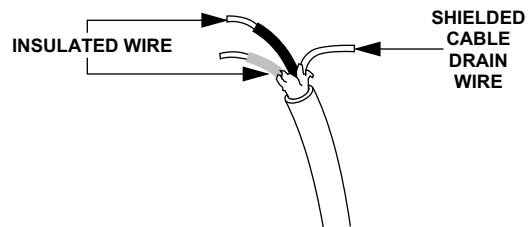

**Figure 5. Shielded Cable Detail**

7. Splice the yellow wire on the AVM to one end of the microphone cable and the other end to the yellow wire on the control panel cable.
8. Replace the AVM cover and screws.

## Powering Up

### To power up the panel and AVM:

1. Make sure all wires are connected correctly and securely crimped.
2. Apply AC and battery power to the panel.

## Programming

Programming the AVM involves entering the following:

- Enabling AVM
- AVM mode of operation
- Fire shutdown
- Panic talk

### Enabling the AVM - Option 33

To allow the user or Central Station use of the AVM, option 33 must be on. To turn option 33 on, follow these steps:

1. Press **Add** from the Start Menu on the Control Panel.
2. Press **Option #, 33**.
3. Press **DONE**.

### Setting the AVM Mode - Option 47

The following describes the available AVM operating modes.

#### Call-back - Option 47 is on

After reporting an alarm, the panel answers on the first ring. A 5 minute window allows remote access alarm verification after an alarm is reported.

This window is activated after an alarm has been reported and allows access to the AVM after one ring at the alarm site. The 5 minute window is cleared when the monitoring service operator hangs up using 99.

#### Instant - Option 47 is off

The central station traps the panel when it reports an alarm. Monitoring personnel can then initiate an audio session from a central station parallel telephone.

### Fire Shutdown - Option 46

#### Shutdown - Option 46 is on

Fire sirens will be shut down at the customer site when audio access is gained. Instead of sirens, the system will beep every ten seconds.

#### Doesn't Shutdown - Option 46 is off

Fire sirens will continue to sound at the customer site when audio access is gained.

The default is off.

To turn Option 46 on:

1. Press **Add** from the control panel's Start Menu.
2. Press **Option #, 46**.
3. Press **DONE**.

### Panic Talk- Option 48

#### Talk - Option 48 is on

The central station operator is able to speak to the person at the customer site during a silent alarm.

#### Listen Only - Option 48 is off

The central station operator is only able to listen to the customer site during a silent alarm. The central station will not be able to put the system into speak mode.

The default is off.

To turn Option 48 on:

1. Press **Add** from the control panel's Start Menu.
2. Press **Option #, 48**.
3. Press **DONE**.

## Testing

The panel must be programmed before testing.

When installation and programming are complete, test the AVM as follows.

## Off-Site Testing

You will need a helper and touch-tone phone at an off-site location to perform this test.

**Note:** Option 27 (Ring, Hang, Ring) must be on to perform the test.

### To test the module from off-site:

1. The off-site helper calls the panel, lets the phone ring once or twice, and hangs up.
2. The helper must call the panel again in 10 to 40 seconds. The panel answers.
3. The helper dials the following on the phone:  
\* **CODE 5**.
4. The helper should dial 1 and be able to speak to you through the AVM.
5. The helper should dial 3 and listen to you.
6. Walk through the vicinity of the AVM while speaking at a normal conversation level.
7. To return to speaking mode, the helper dials 1.
8. When testing is complete, have the helper dial 99 to hang up.

## Central Station Testing

You can also use the central station to test the module.

### To test the module from the central station:

1. Inform the central station that you will be sending an alarm and testing an AVM.
2. Give them the programming selections you made for the panel.
3. Use a touchpad panic button to initiate an auxiliary alarm.
4. The central station operator waits for the alarm to be reported and initiates an audio session.
5. Have the operator speak to you.
6. Tell the operator to press 3 and walk through the vicinity of the AVM while speaking at a normal conversation level.
7. When testing is complete, the operator will end the session by pressing 99.

## Sound Volume

The AVM microphone volume is automatically controlled and is not adjustable. The speaker volume is preset to full volume.

## If It Doesn't Work

AVM communication failure usually occurs because of panel programming errors. Check the programming

selections you made at the panel.

## Specifications

Power Requirements: 12 VDC, 10 mA (maximum)

Dimensions: 6.9" L x 4.9" H x 2.5" D

Color: Belgian Grey

## Notices

This device complies with part 15 of the FCC rules. Operation is subject to the following two conditions:

- 1) This device may not cause harmful interference.
- 2) This device must accept any interference received, including interference that may cause undesired operation.

Changes or modifications not expressly approved by Interactive Technologies, Inc. can void the users' authority to operate the equipment.



WIRELESS

Security  
Automation  
Access Control

2266 SECOND STREET NORTH  
NORTH SAINT PAUL, MN 55109

T: 651-777-2690

F: 651-779-4890

ITI, Simon, and Interrogator are registered trademarks of Interactive Technologies, Inc. .